



# EPT20-18EA

## Electric Pallet Truck 1.8t

- **Delivery Truck:** The Last Mile Solution Truck  
Customised for Half Pallet Handling, Dock Tail Trailer
- **Applicable Industry:** Mailing, Beverage, Food, Retail, Convenient Stores, etc.

EP EQUIPMENT CO.,LTD  
[www.ep-ep.com](http://www.ep-ep.com)

# Electric Pallet Truck 1.8t EPT20-18EA

Distinguishing mark						
1.1	Manufacturer				EP	
1.2	Model designation				EPT20-18EA	
1.3	Drive unit				Electrics	
1.4	Operator type				pedestrian	
1.5	rated capacity	Q	lb.	kg	1800	
1.6	Load center distance	c	in.	mm	600	
1.7	Load distance	x	in.	mm	945	
1.9	Wheelbase	y	in.	mm	1270	
Weight						
2.1	Service weight (include battery)		lb.	kg	285	
2.2	Axle loading, laden driving side/loading side		lb.	kg	770/1315	
2.3	Axle loading, unladen driving side/loading side		lb.	kg	230/55	
Types,Chassis						
3.1	Tyre type driving wheels/loading wheels				polyurethane/ polyurethane	
3.2	Tyre size, driving wheels (diameter×width)		in.	mm	Φ230×75	
3.3	Tyre size, loading wheels (diameter×width)		in.	mm	Φ74×88 / Φ80×60	
3.4	Tyre size, caster wheels (diameter×width)		in.	mm	Φ85×48	
3.5	Wheels, number driving, caster/loading (x=drive wheels)		in.	mm	1x2/2 / 1x2/4	
3.6	Track width, front,driving side	b <sub>10</sub>	in.	mm	435	
3.7	Track width,rear,loading side	b <sub>11</sub>	in.	mm	390/495/535	
Dimensions						
4.4	Lift height		h <sub>3</sub>	in.	mm	115
4.9	Height drawbar in driving position min./max.		h <sub>14</sub>	in.	mm	715 / 1200
4.15	Lowered height		h <sub>13</sub>	in.	mm	85
4.19	Overall length		l <sub>1</sub>	in.	mm	1625
4.20	Length to face of forks		l <sub>2</sub>	in.	mm	475
4.21	Overall width		b <sub>1</sub> / b <sub>2</sub>	in.	mm	645
4.22	Fork dimensions		s / e / l	in.	mm	50x150x1150
4.25	Distance between fork-arms		b <sub>5</sub>	in.	mm	540/645/685
4.32	Ground clearance, center of wheelbase		m <sub>2</sub>	in.	mm	35
4.34.1	Aisle width for pallets 1000 × 1200 crossways		Ast	in.	mm	1720
4.34.2	Aisle width for pallets 800 × 1200 lengthways		Ast	in.	mm	1920
4.35	Turning radius		Wa	in.	mm	1465
Performance data						
5.1	Travel speed, laden/ unladen		km/ h	mph	km/h	5.5/6
5.2	Lifting speed, laden/ unladen			fpm	m/ s	0.051/ 0.060
5.3	Lowering speed, laden/ unladen			fpm	m/ s	0.032/ 0.039
5.8	Max. gradeability, laden/unladen				%	6/16
5.10	Service brake type					Electromagnetic
Electric-engine						
6.1	Drive motor rating S2 60 min			hp	kW	1.1
6.2	Lift motor rating at S3 15%			hp	kW	0.84
6.3	The maximum allowed size battery			in.	mm	269x182x300
6.4	Battery voltage/nominal capacity K20			V/ Ah		2x 12/85
6.5	Battery weight			lb.	kg	25 x2
Addition data						
8.1	Type of drive control					AC
10.5	Steering type					Mechanical
10.7	Sound pressure level at the driver's ear				dB (A)	74

- 1.The parameters in the table are of the standard model. For more information, please contact us.
- 2.The parameters are subject to change without notice.

Solution Packages:





- World' s 1st Half Pallet Truck
- High Traction, Indoor and Outdoor Perfect Handling
- Long Battery Running Time, Larger Battery Installment Option, Full day Job Handling
- Small Turning Radius, Excellent Maneuverability Inside Trailer
- On-board Charger, Easy to Charge
- Customized Solution Available

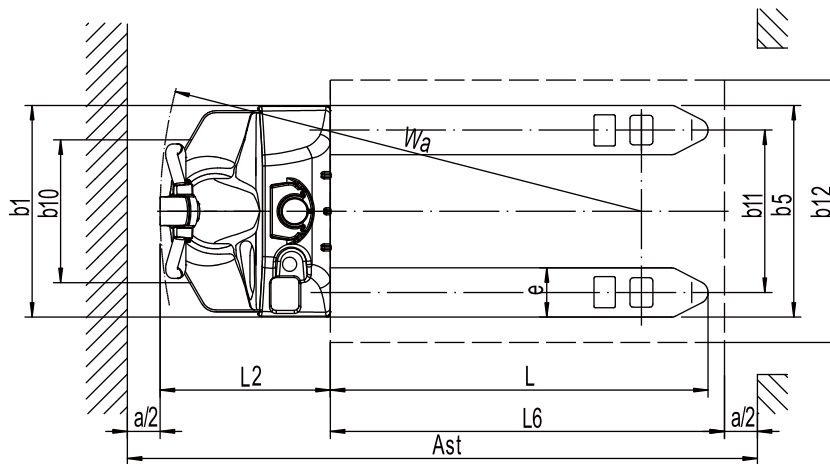
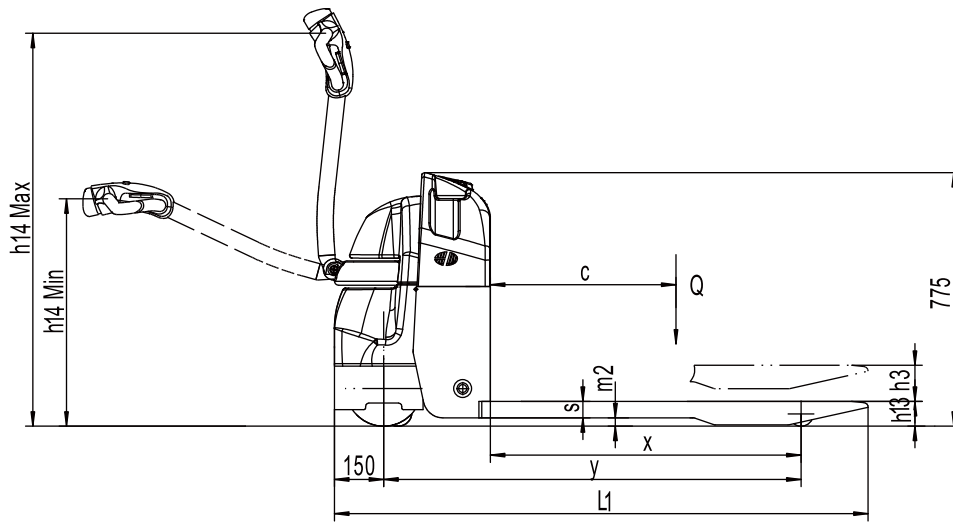

## Option

Options	EPT20-18EA
Fork length	● 850/915/1000/1150/1185/1220/1300/1450mm
Fork lowered height	● 85mm
Driving wheel	● Rubber
Balance wheel	●
high capacity battery	● 60AH/85AH/120AH
Cold storage	●
battery indicator with hour meter	●
water auto-filling system	●
Special backrest	● 1220mm (48in)/1520mm (60in)